



SPEED QUEEN® MULTI-HOUSING LAUNDRY SOLUTIONS

Stack Classic Tumble Dryer

STT30

30 lb (14 kg)

Built for Reliable Performance

Our line of stack tumble dryers provides double the capacity of Speed Queen® single pocket tumble dryers while using only half the floor space.

- Large easy-to-clean lint compartment
- Fewer moving parts mean fewer maintenance problems and less wear

- High performance heater box increases energy efficiency, reduces drying times and provides a more comfortable operating environment
- Axial airflow pattern with the sealed cylinder rims delivers the fastest and most efficient drying results
- Two drying pockets in the space of one unit helps increase drying capacity
- Single gas, electric and exhaust hookups simplify installation and are less expensive than installing twice the number of single units



Quantum® Gold

In addition to its network capabilities and off-site management features, Quantum® Gold offers additional owner and customer benefits such as PC/PDA programming and machine audit capabilities, as well as time-of-day pricing of up to a year in advance, a free "lucky cycle" for loyal customers and the ability to interface with the store owner's card manufacturer of choice. As gas prices continue to rise, Quantum Gold enables you to set dry cycle times right down to the second for maximum profitability.

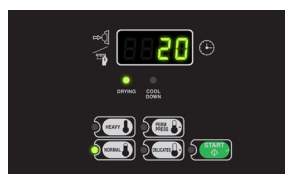

Micro-Display

Our Micro Display Control (MDC) clearly displays the vend price and keeps customers informed throughout the drying process with cycle status lights and a digital cycle countdown. Interfacing with a variety of aftermarket card reader systems, MDC offers four cycle selections, basic audit features and comes installed with a single coin drop.

Stack Classic Tumble Dryer

Specifications

		STT30	
Control Option		Quantum Gold, MDC	
Capacity - lb (kg)		2 x 30 (14)	
Overall Width - in (mm)		31.5 (800)	
Overall Depth - in (mm)		42.75 (1086)	
Overall Height - in (mm)		76.25 (1937)	
Cylinder Diameter - in (mm)		30 (762)	
Cylinder Depth - in (mm)		26 (660)	
Cylinder Volume - cu. ft (liters)		10.6 (300)	
Reversing Cylinder		Option	
Door Opening Size - in (mm)		22.7 (576)	
Heat Input Power	Gas Models - Per Pocket	146,000 Btu/hr	
	Electric Models	21kW	
Gas Connections - in (npt)		0.5	
Air Outlet - in (mm)		1 x 8 (203)	
Motor - HP	Fan	0.5	
	Cylinder	0.5	
Airflow - cfm	50 Hz	340 (160)	
	60 Hz	400 (189)	
Electrical Specs - amps	Gas		
	F6	200-208/240V/60/3 3W+G	6.4/6.4
	J2	230-240V/50/1 2W+G	15.0
	B2	120/208-240V/60/1 2W/3W+G	16/8.0
	A2	100/200-220V/60/1 2W+G	22/11.6
	A1	100/200V/50/1 2W+G	24.2/15.0
	N1	400-415V/50/3	3.0/3.2
	Electric		
M1	380V/50/3 3W+G	66	
N1	400-415V/50/3 3W+G	62	
Shipping Dimensions Approx.- in (mm)	Width	32.5 (830)	
	Depth	47 (1190)	
	Height	81 (2057)	
Net Weight - lb (kg)		544 (247)	
Shipping Weight - lb (kg)		582 (264)	
Agency Approvals		CSA	

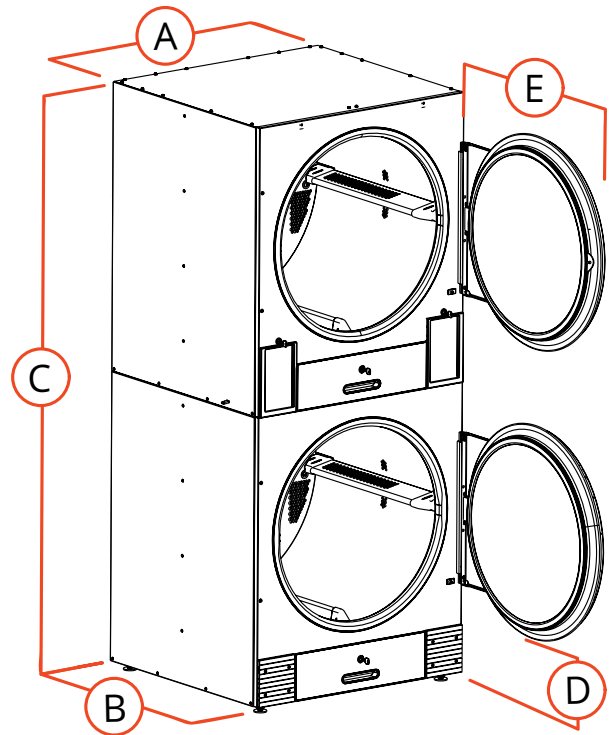

A. Overall Width - in (mm)	31.5 (800)
B. Overall Depth - in (mm)	42.75 (1086)
C. Overall Height - in (mm)	76.25 (1937)
D. Door Bottom to Floor - in (mm)	10.7 (272)
E. Door Swing - in (mm)	28 (711)

Tumble dryer models are made to suit a variety of electrical service characteristics. See your Speed Queen route operator for specifications. For further details on installation, refer to Installation, Operation and Maintenance instructions supplied with the tumble dryer. Amperage ratings available in Installation Manual. For the most accurate information, the installation guide should be used for all design and construction purposes. Due to continuous product improvements, design and specifications subject to change without notice. The quality management systems of Alliance Laundry Systems are registered to ISO 9001.